

The SMI-8 is a 8 channel interface for use with all SM1 series microphones. It provides a convenient way of supplying power to the SM1, installer friendly termination of the cable runs and standard RCA or 3.5mm audio output connectors. The SMI-8 easily connects to recording equipment such as DVRs and audio recorders. Note the audio output signals of the SMI-8 are “line level” (0dbm).

**SM1 Microphone Placements**

Locate the SM1 microphones as close as possible to the areas of interest in the spaces to be monitored. If large areas are to be monitored, locate the SM1s in the middle of the rooms. Do not mount the microphones near air conditioning vents, light fixtures or electrical equipment. The SM1 should be placed as close as possible to the subject(s) to be monitored. The SM1s are useable at distances of up to 25 feet but is dependent on the level of background noise in the areas. Experimentation in the environment will determine what distances work best.

**Mounting**

The SM1s can be surface or flush mounted on ceilings or walls. For flush mounting, cut a 2 ¼” by 2 ¾” hole in the wall or ceiling tile to allow room for the circuit board and mount the SM1 to the surface with screws. For surface mounting applications, Purchase SM1-LEs. Or use a single gang electrical boxes.

**SMI-8 location and power**

The SMI-8 interface box is designed to be located next to a DVR or IP camera. The SMI-8 requires a 120VAC power source within 3 feet of its location. If this is not possible in your application, you can splice in up to 100 feet of 20 awg, 2 conductor cable to extend the distance between the AC power source and the SMI-8.

**Cable Runs**

Run 8 each, 22 gauge, stranded, two conductor shielded cables between the SMI-8 interface and the SM1 microphones. Keep the cable run distances under 1,000 feet and away from AC power sources, light fixtures and electrical equipment. *See Figure 1 for connection diagram.*

**Adjusting the SM1 Gain**

The SM1 output level is set by selecting the desired volume range and adjusting the gain control.

The “Volume Range” switch should be set to the “LO” position when using the SM1 with IP cameras that utilize “microphone inputs” also known as “Mic. Level” inputs. This sets the maximum gain of the SM1’s pre-amp to x14. The switch should be placed in the “HI” position when using IP cameras with “Line level” inputs of DVRs and IP cameras. This sets the maximum gain of the SM1’s pre-amp to x196.

The SM1 is shipped with the gain set at midrange. If the sound at the “head end” is distorted, rotate the control towards the – mark (counter-clockwise). If the volume at the “head end” is too low, rotate the control towards the + mark (clockwise).

**Setting the SM1 Hi-Cut/Lo-Cut Switches (open the enclosure to adjust)**

The normal frequency response of the SM1 microphone is 500-13Khz. When both switched “in”, The “HI Cut” and “Lo Cut” filters set the SM1’s frequency response to 900-6Khz. Enabling one or both of the filters is useful when background noise needs to be further reduced and intelligibility of speech emphasized. We recommend experimenting with the switch settings to achieve the best acoustic result for your application.

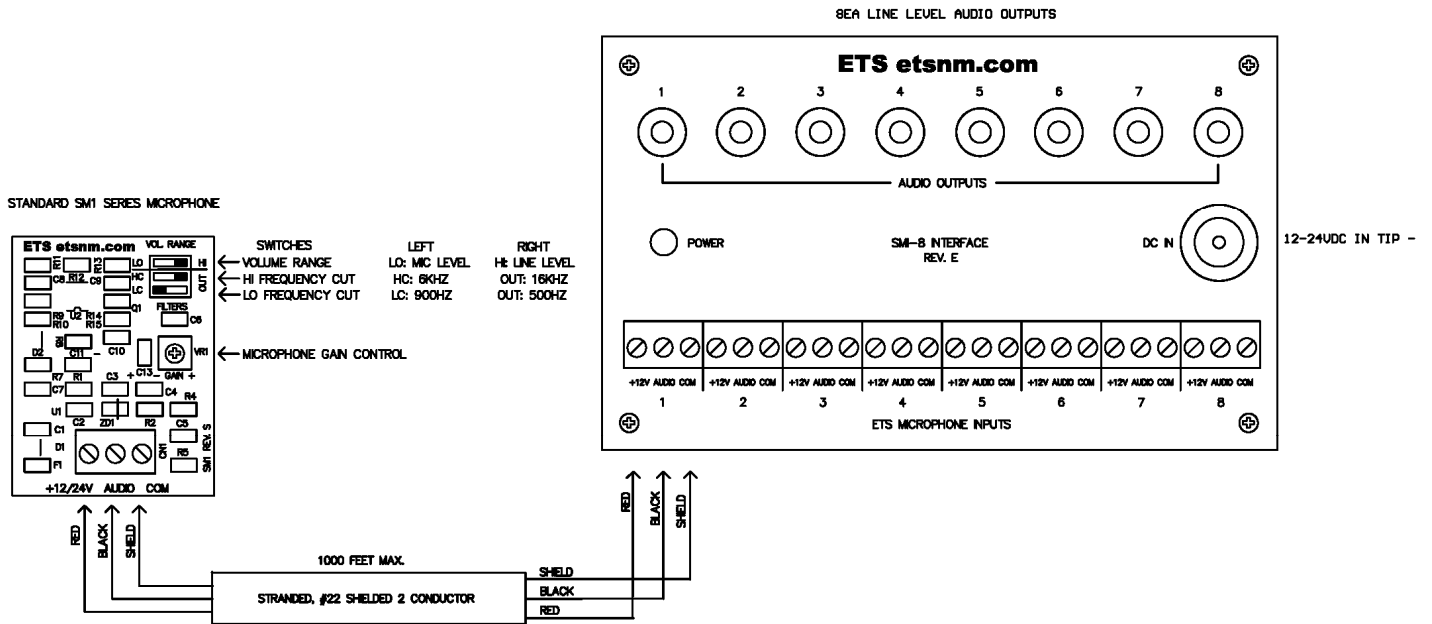

Figure 1.

### Caution

It may be against the law to install this microphone kit in certain environments. It may also be against the law to record conversations of the person(s) being monitored without their knowledge. It is the responsibility of the installation company and end-user to determine if the application of this product is legal. These laws vary from state to state. If you are not informed on these matters, consult a qualified attorney or contact the appropriate state agency. A sticker is provided with this kit for the applications where notification must be posted.

### Warranty

All ETS products carry a one year parts and labor warranty. This warranty does not cover damages as a result of misuse, improper handling of the unit or exposure to extreme temperatures or moisture. At its discretion, ETS reserves the right to repair or replace this unit under the conditions of the warranty. If you experience problems with your equipment call ETS at: 505-888-3923 to obtain a return authorization number. Equipment requiring repair beyond the warranty period or units that have been damaged or are not covered under the warranty can be repaired by ETS for a minimal cost under most conditions.

Made in the USA  
by  
**ETS Inc.**