

The CSM8-C5 is a two-way audio surveillance system (intercom accessory) designed to be used with DVRs, I/P cameras etc. Note- the CSM8-C5 can only be used with compatible ETS DVR & I/P camera interfaces. CSM8-C5s are suitable for both indoor and outdoor applications. **Note- to prevent unwanted feedback, use this product with systems supporting PTT (push to talk) half duplex audio or full duplex audio systems using acoustic echo cancelling technology.**

CSM8-C5 Speaker / Microphone Placement.

Locate the CSM8-C5 as close as possible to the area of interest in the space to be monitored. If a large area is to be monitored, locate the CSM8-C5 in the middle of the space if possible. Do not mount the CSM8-C5 near air conditioning vents, light fixtures or electrical equipment. The CSM8-C5 operates optimally at a distance of 3-5 feet from the subject(s) to be monitored. The CSM8-C5 is still useable in the range of 15-25 feet but is dependent on the level of background noise in the area. Experimentation in the environment will determine what distances work best.

Cable Run

Run a single CAT5 cable from the CSM8-C5 Speaker / Microphone and the SMAx-LP interface box. Keep the cable run distance at or below 500 feet and away from AC power sources, light fixtures and electrical equipment. Wire the RJ45 cable connectors in the following order:

Pair 1	1	CALL SW
	2	CALL SW
Pair 2	3	SPEAKER (70V) +
	4	SPEAKER (70V) –
Pair 3	5	MICROPHONE +
	6	MICROPHONE –
Pair 4	7	+12V (MICROPHONE)
	8	COM (MICROPHONE)

Call Switch Connections

The CSM8-C5 features a call switch input. This pair of wires is isolated from all other circuitry and can be used for a call switch, door contact, door release relay, etc. Terminal block connections are “broken out” on the CSM8-C5 and any ETS SMAx-LP interface ordered with the –C5 option. Note- if the CSM8-C5 was ordered with a call switch, the call switch terminal block will not be available for other uses.

Adjusting the Microphone “Gain” and SMAx-LPxx-C5 “Level” controls (audio output)

If the SMAx-LPxx-C5 will be plugged into a “microphone level” input of an I/P camera, set the “volume range” jumper of the CSM8-C5’s microphone to the “LO” position and set the microphone “GAIN” full clockwise. Then use the “level control” on the SMAx-LPxx-C5 to set a volume that produces an acceptable audio level at the head end.

If the SMAx-LPxx-C5 will be used with a “line level” input, set the “volume range” jumper of the CSM8-C5’s microphone to the “LO” position and set the microphone “GAIN” full clockwise. Then, adjust the level control on the SMAx-LPxx-C5 to produce the clearest audio level at the head end.

Setting the CSM8-C5 Microphone Hi-Cut/Lo-Cut Jumpers

The normal frequency response of the CSM8-C5 microphone is 500-13Khz. When both jumpered “in”, The “HI Cut” and “Lo Cut” filters set the STW1’s frequency response to 900-6Khz . Enabling one or both of the filters is useful when background noise needs to be further reduced and intelligibility of speech emphasized. We recommend experimenting with the jumper settings to achieve the best acoustic result for your application.

Note- CSM8-C5 speaker volume can only be adjusted on the SMAx-LPxx-C5 at the other end of the system.

SPEAKER POWER TAPS:
LEAVE IN 2W POSITION

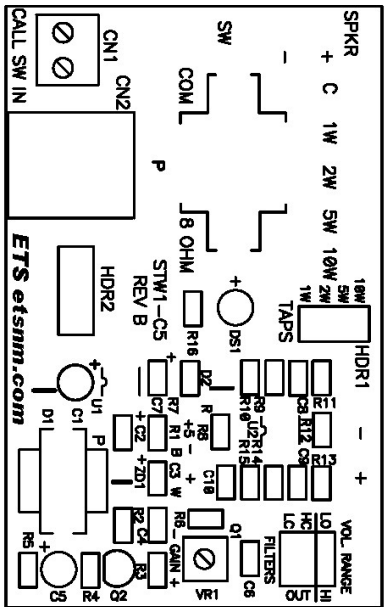

MICROPHONE JUMPERS:

VOLUME RANGE LEFT RIGHT
HI FREQUENCY CUT ON: 6KHZ OFF: 13KHZ
LO FREQUENCY CUT ON: 900HZ OFF: 500HZ

← MICROPHONE GAIN CONTROL

IMPORTANT
INSTALL WIRES IN RJ45 PLUG IN THE FOLLOWING ORDER
DO NOT WIRE AS A STANDARD ETHERNET CABLE!!!

- PAIR 1 < 1 CALL SW
- PAIR 2 < 2 CALL SW
- PAIR 3 < 3 SPEAKER (70V) +
- PAIR 4 < 4 SPEAKER (70V) -
- PAIR 5 < 5 MICROPHONE +
- PAIR 6 < 6 MICROPHONE -
- PAIR 7 < 7 +12V (MICROPHONE)
- PAIR 8 < 8 COM (MICROPHONE)

OPTIONAL CALL SWITCH OUTPUT
OR DOOR RELAY INPUT

TO DVR OR I/P CAMERA *AUDIO IN*

TO DVR OR I/P CAMERA *AUDIO OUT*

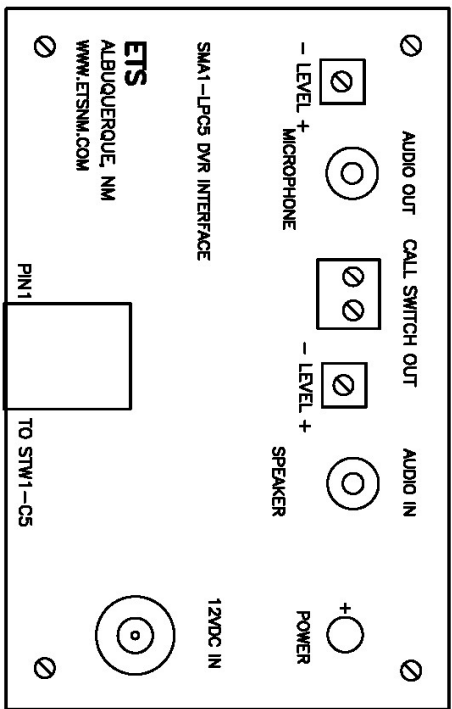

TO 12VDC AC ADAPTOR.
UP TO 100 FT #18 2 CONDUCTOR
IS PERMISSIBLE

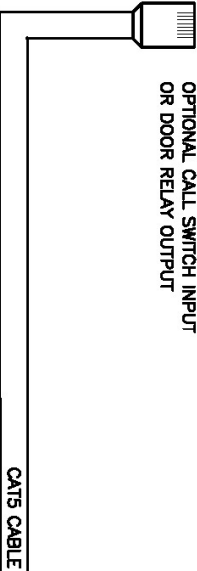

CONNECTIONS TO SMA1-LPC5 (FOR EXAMPLE)

Caution

It may be against the law to install this microphone kit in certain environments. It may also be against the law to record conversations of the person(s) being monitored without their knowledge. It is the responsibility of the installation company and end-user to determine if the application of this product is legal. These laws vary from state to state. If you are not informed on these matters, consult a qualified attorney or contact the appropriate state agency. A sticker is provided with this kit for the applications where notification must be posted.

Warranty

All ETS products carry a one year parts and labor warranty. This warranty does not cover damages as a result of misuse, improper handling of the unit or exposure to extreme temperatures or moisture. At its discretion, ETS reserves the right to repair or replace this unit under the conditions of the warranty. If you experience problems with your equipment call ETS at: 505-888-3923 to obtain a return authorization number. Equipment requiring repair beyond the warranty period or units that have been damaged or are not covered under the warranty can be repaired by ETS for a minimal cost under most conditions.

Made in the USA
by
ETS Inc.