

The STW1-W4 is a two-way audio surveillance system (intercom accessory) designed to be used with DVRs, IP cameras etc. Note- STW1-W4s are not recommended for outdoor use where they may be exposed to water. **Note- to prevent unwanted feedback, use this product with systems supporting PTT (push to talk) half duplex audio or full duplex audio systems using acoustic echo cancelling technology.**

#### **STW1-W4 Microphone / Speaker Placement.**

Locate the STW1-W4 as close as possible to the area of interest in the space to be monitored. If a large area is to be monitored, locate the STW-W4 in the middle of the space if possible. Do not mount the STW1-W4 near air conditioning vents, light fixtures or electrical equipment. The STW1 operates optimally at a distance of 3-5 feet from the subject(s) to be monitored. The STW1 is still usable in the range of up to 25 feet but is dependent on the level of background noise in the area. Experimentation in the environment will determine what distances work best.

#### **Cable Runs**

Run 2 each 22 gauge, stranded, two conductor shielded cable between the STW1-W4 microphone / speaker and the interface equipment. Keep both cable run distances under 250 feet and away from AC power sources, light fixtures and electrical equipment. *See connection diagrams below.*

#### **Mounting**

Mount the STW1-W4 on walls or ceilings using the provided hardware. Note where the microphone is and orient it in the general direction of the area of interest.

#### **STW1-W4 Optional Call Switch**

Connect this switch (STW1 terminals cs1 and cs2) to equipment that permits a “page” signal input. It is a N.O. (normally open) dry switch contact. Use a 22awg 2 conductor for this cable run.

#### **Speaker Line / 70v switch**

If you are using a “line level” (0db) audio signal input for the speaker, make connections as shown in the first drawing below and place the input switch in the “line” position. If you are using a “70v” audio input for the speaker, make connections as shown in second drawing below and place the input switch in the “70v” position.

#### **Adjusting the STW1-W4 Speaker Gain and Speaker Volume**

Begin with a midrange setting of the gain control on the STW1-W4. If it is determined that the speaker volume is too low when the volume is set full clockwise, move the “volume range” jumper to the “HI” position. Then, re-adjust the “SPKR VOLUME” control + or – for maximum microphone clarity. If the sound at the DVR is distorted, rotate the control towards the – mark (counter- clockwise). If the volume at the amplifier is too low, rotate the control towards the + mark (clockwise). Adjust the “talk-back” speaker volume to the appropriate level.

#### **Setting the STW1-W4 Microphone Gain**

The STW1-W4 output level is set by selecting the desired volume range and adjusting the gain control.

The “Volume Range” jumper should be set to the “LO” position when using the STW1-W4 with IP cameras that utilize “microphone inputs” also know as “Mic. Level” inputs. This sets the maximum gain of the STW1-W4’s pre-amp to x14. The jumper should be placed in the “HI” position when using IP cameras with “Line level” inputs of DVRs and IP cameras. This sets the maximum gain of the STW1-W4’s pre-amp to x196.

The STW1-W4 is shipped with the gain set at midrange. If the sound at the “head end” is distorted, rotate the control towards the – mark (counter-clockwise). If the volume at the “head end” is too low, rotate the control towards the + mark (clockwise).

#### **Setting the STW1-W4 Microphone Hi-Cut/Lo-Cut Jumpers**

The normal frequency response of the STW1-W4 microphone is 500-13Khz. When both jumpered “in”, The “HI Cut” and “Lo Cut” filters set the STW1-W4’s frequency response to 900-6Khz . Enabling one or both of the filters is useful when

background noise needs to be further reduced and intelligibility of speech emphasized. We recommend experimenting with the jumper settings to achieve the best acoustic result for your application.

INPUT SELECT MUST BE IN "LINE" POSITION FOR USE WITH STWI INTERFACE BOXES

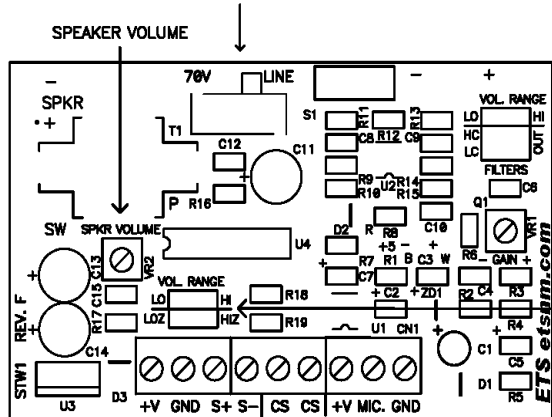

MICROPHONE JUMPERS:

VOLUME RANGE	LEFT LO: MIC LEVEL	RIGHT HI: LINE LEVEL
HI FREQUENCY CUT	ON: 6KHZ	OFF: 13KHZ
LO FREQUENCY CUT	ON: 900HZ	OFF: 500HZ

← MICROPHONE GAIN CONTROL

SPEAKER JUMPERS:

VOLUME RANGE	LEFT LO: -10DB	RIGHT HI: 0DB
INPUT IMPEDANCE (Z)	1K OHMS	10K OHMS

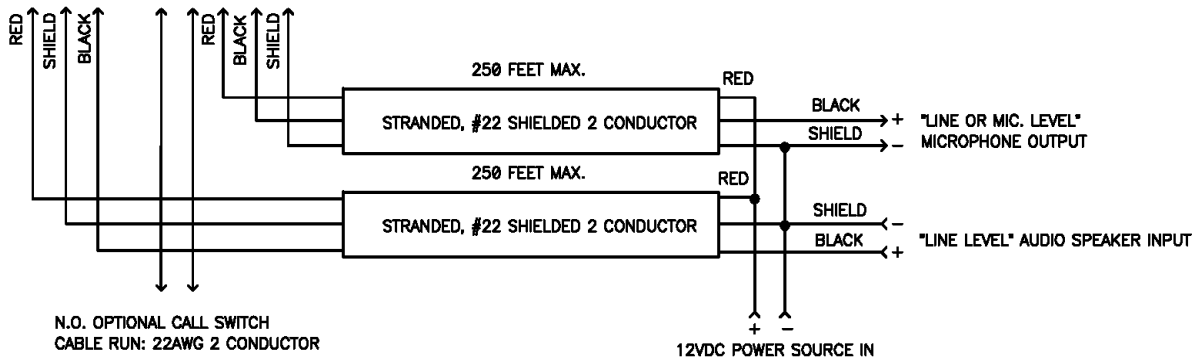

### LINE/MIC. MICROPHONE OUTPUT AND LINE LEVEL SPEAKER INPUT

INPUT SELECT MUST BE IN "70V" POSITION FOR USE WITH ETS TWO WAY BASE STATIONS.

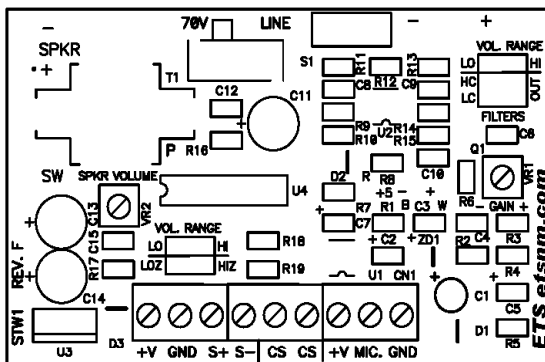

NOTE- VOLUME CONTROL FOR SPEAKER IS INOPERATIVE IN 70V MODE.

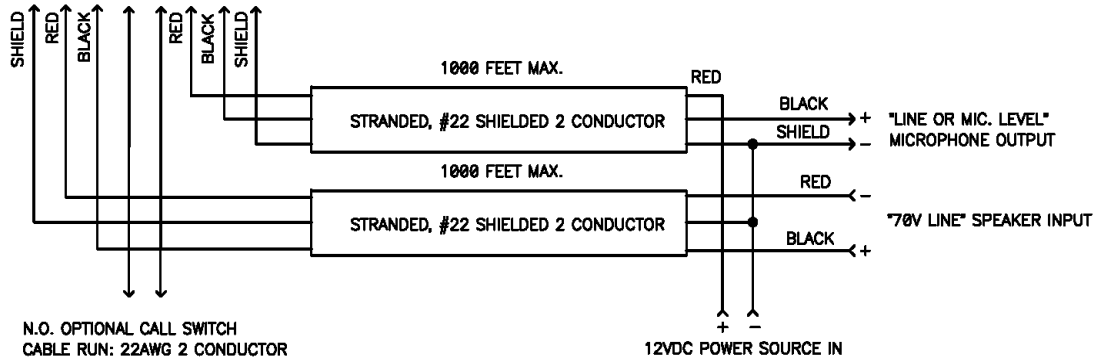

### LINE/MIC. LEVEL MICROPHONE OUTPUT AND 70V SPEAKER INPUT

### **Caution**

It may be against the law to install this microphone kit in certain environments. It may also be against the law to record conversations of the person(s) being monitored without their knowledge. It is the responsibility of the installation company and end-user to determine if the application of this product is legal. These laws vary from state to state. If you are not informed on these matters, consult a qualified attorney or contact the appropriate state agency. A sticker is provided with this kit for the applications where notification must be posted.

### **Warranty**

All ETS products carry a one year parts and labor warranty. This warranty does not cover damages as a result of misuse, improper handling of the unit or exposure to extreme temperatures or moisture. At its discretion, ETS reserves the right to repair or replace this unit under the conditions of the warranty. If you experience problems with your equipment call ETS at: 505-888-3923 to obtain a return authorization number. Equipment requiring repair beyond the warranty period or units that have been damaged or are not covered under the warranty can be repaired by ETS for a minimal cost under most conditions.

**Made in the USA**  
by  
**ETS Inc.**