

ETSInc. MTDC-2 Two Door Access Control Interlock

The MTDC-2 is a 2 door access control Interlock (man trap) board designed to be used with two standalone access control readers or two networked access control readers. The MTDC-2 accepts door contact inputs and lock release inputs from 2 access control readers and controls the lock release functions and traffic LED states according to the door states and the board's interlock logic. The MTDC-2 also has a pass through mode only requiring two door contacts for inputs.

Power Input (+12/24v-)

The MTDC-2 accepts 12-24Vdc at 2 amps maximum. The input power is also routed to the lock control outputs. The lock control outputs are auto-reset fused in the event a lock fails-shortened. See figure 1.

Door Override Input (+OVR-)

The MTDC-2 OVR input accepts a 5-24vdc input Voltage or a NC dry relay contact input. The factory default is for a NC input. See Figure 2 for jumper settings to set the board to accept a Voltage input. This input overrides all interlock functions and opens both doors immediately. If traffic lights are connected to the MTDC-2, the red and green LEDs will flash back and forth at .5 Hz. Once the override is removed the system resumes normal operation. See figure 1.

Traffic Light Status Outputs (5V RD GN)

The MTDC-2 allows the connection of up to 4 TLP-SS traffic light indicators to prompt persons using the interlock system for "GO" and "STOP" situations. Below is a table of the various LED indications. See figure 1.

Green LED	Red LED	Condition
On solid	Off	Both doors secured, ready for a card read.
Off	On Solid	One or both doors are open, both must be closed to clear
Off	Flashing	Interlock timer is activated. User must wait for Green LED
Flashing	Flashing	Door override input is activated and both doors unlocked.

Note- After a valid card read, the green LED will stay lit until the door is opened.

Interlock Timer Output Relay (NC C NO)

This output changes state when the interlock timer is activated and the contacts are rated for 2 Amps. If the interlock timer delay control is set to 0, this output changes state for 1 second. See figure 1.

Interlock Timer Delay (Delay)

This control allows for a delay between when the first door opens and when the second door is permitted to be opened. During the adjustable delay of 0-60 seconds, The NC C NO output will change state. This output can be used to trigger decontamination fans or other equipment. If the delay time is set to 0, the delay timer does not function. During the interlock time interval, the red LED output will flash at a rate of 1/2Hz. See figure 1.

Door Contact Input (IN)

A NC (normally closed) door contact must be connected to these inputs for both doors in order for the MTDC-2 to function. See figure 1.

Door Contact Output (OUT)

This is a normally closed output that follows the state of the door contact input (IN). It is provided to report door status to the connected access control reader to indicate forced door, door propped or auto-lock on door opened conditions. See figure 1.

Door Unlock Input (-LC+)

The MTDC-2 LC input accepts a 5-24vdc input Voltage or a NO dry relay contact input. The factory default is for a NO contact input. The See Figure 3 for jumper settings to set the board to accept a dry contact input. operation.

Door Lock Output (COM NNV NV)

The locks are connected directly to these outputs. These outputs can supply up to 1 Amp at 12-24Vdc. NNV stands for Normally No Voltage and NV stands for Normally Voltage. See figure 1.

NOTE- Be sure to install transient protection diodes (such as type 1N5819) when using door strikes. Maglocks can be directly connected to the board. See figure 1.

PASS THROUGH MODE

Set switch 1 to ON position to select this mode. In pass through mode, both doors always remain unlocked and the traffic light is green when both doors are closed. When door 1 contact opens, door 2 locks and the traffic light turns red. When both doors are closed again, the locks unlock and the traffic light is green. When door 2 is open, door 1 locks and he traffic lights behave as previously described. The Lock control inputs do not function in this mode. If the override input is energized, both doors remain open no matter what. See figure 2.

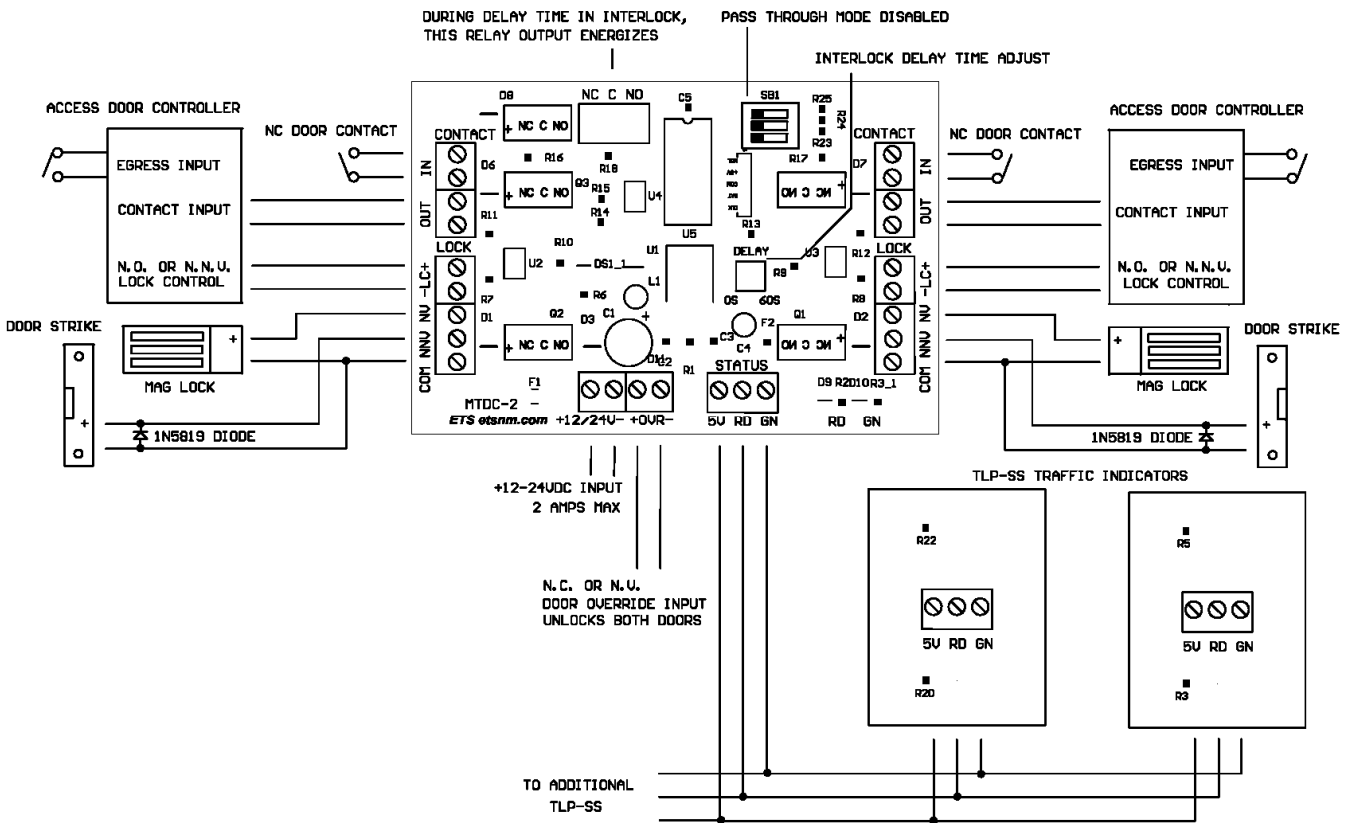

Figure 1 Access control mode.

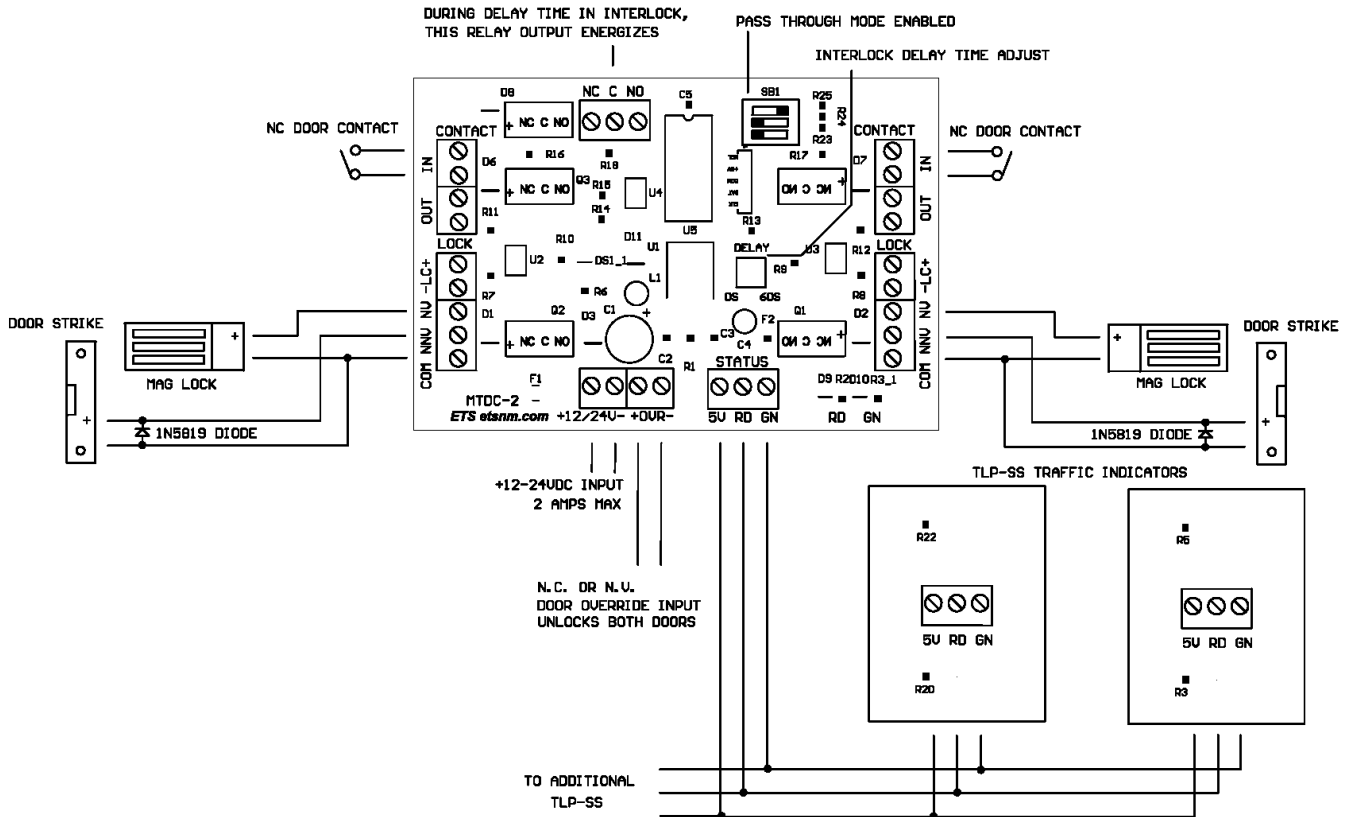

Figure 2 Pass through mode

BOTTOM VIEW OF BOARD

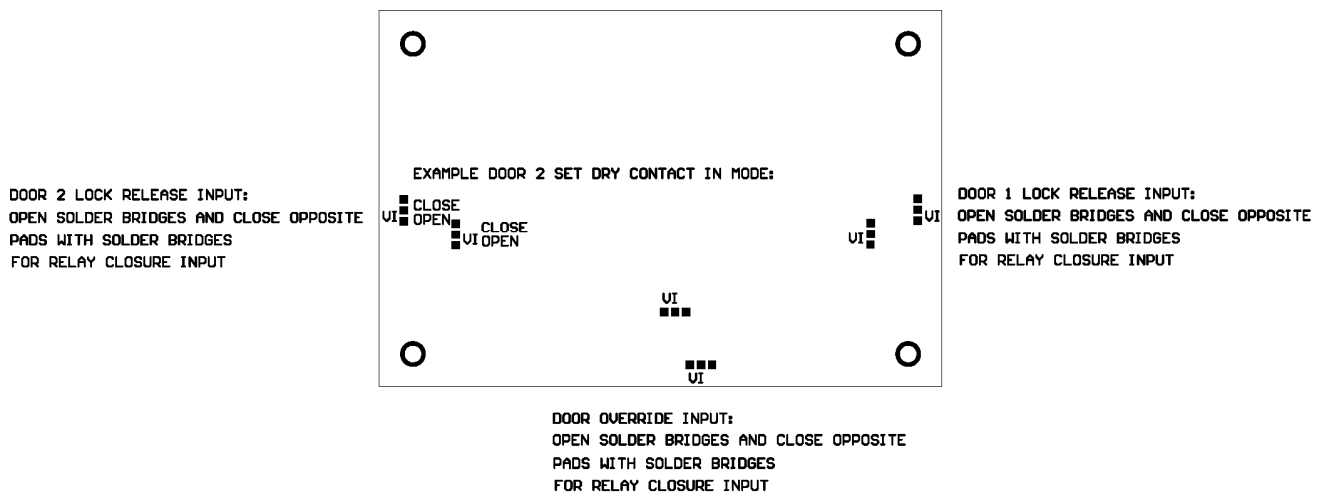

Figure 3 Configuring voltage in to dry contact in

Warranty

All ETS products carry a one year parts and labor warranty. This warranty does not cover damages as a result of misuse, improper handling of the unit or exposure to extreme temperatures or moisture. At its discretion, ETS reserves the right to repair or replace this unit under the conditions of the warranty. If you experience problems with your equipment call ETS at: 505-888-3923 to obtain a return authorization number. Equipment requiring repair beyond the warranty period or units that have been damaged or are not covered under the warranty can be repaired by ETS for a minimal cost under most conditions.

Made in the USA

by

ETS Inc.